



US010236328B2

(12) **United States Patent**
Kim et al.

(10) **Patent No.:** **US 10,236,328 B2**
(45) **Date of Patent:** **Mar. 19, 2019**

(54) **METHOD OF MANUFACTURING ORGANIC LIGHT-EMITTING DISPLAY DEVICE**

(71) Applicant: **SAMSUNG DISPLAY CO., LTD.**,
Yongin-si, Gyeonggi-do (KR)

(72) Inventors: **Jaesik Kim**, Yongin-si (KR); **Yeonhwa Lee**, Yongin-si (KR); **Joongu Lee**, Yongin-si (KR); **Schoon Jeong**, Yongin-si (KR)

(73) Assignee: **SAMSUNG DISPLAY CO., LTD.**,
Yongin-si, Gyeonggi-do (KR)

(*) Notice: Subject to any disclaimer, the term of this patent is extended or adjusted under 35 U.S.C. 154(b) by 0 days.

(21) Appl. No.: **15/831,829**

(22) Filed: **Dec. 5, 2017**

(65) **Prior Publication Data**
US 2018/0277612 A1 Sep. 27, 2018

(30) **Foreign Application Priority Data**
Mar. 23, 2017 (KR) 10-2017-0036921

(51) **Int. Cl.**
H01L 27/32 (2006.01)
H01L 51/52 (2006.01)
H01L 51/00 (2006.01)

(52) **U.S. Cl.**
CPC **H01L 27/3248** (2013.01); **H01L 27/3211** (2013.01); **H01L 51/004** (2013.01);
(Continued)

(58) **Field of Classification Search**
CPC H01L 27/3248; H01L 27/3211; H01L 51/5253; H01L 51/004; H01L 51/56
See application file for complete search history.

(56) **References Cited**

U.S. PATENT DOCUMENTS

8,513,038 B2 8/2013 Moriyama et al.
9,054,341 B2 6/2015 Kim et al.
(Continued)

FOREIGN PATENT DOCUMENTS

JP 2013-114805 A 6/2013
JP 2014-232568 A 12/2014
(Continued)

OTHER PUBLICATIONS

Barry Arkles, Silane Coupling Agents Connecting Across Boundaries, (3ed Edition), Gelest, Inc, Morrisville, PA.

Primary Examiner — Jay C Chang

Assistant Examiner — Mikka Liu

(74) *Attorney, Agent, or Firm* — Lee & Morse P.C.

(57) **ABSTRACT**

A method of manufacturing an organic light-emitting display device includes forming pixel electrodes on a substrate, forming a first protective layer with a first exposure portion that exposes a first pixel electrode of the pixel electrodes, forming on the first pixel electrode a first intermediate layer and a first blocking layer covering the first intermediate layer, removing the first protective layer, forming a second protective with a second exposure portion that exposes a second pixel electrode of the pixel electrodes, forming on the first pixel electrode a second intermediate layer and a second blocking layer covering the second intermediate layer, removing the second protective layer, forming a third protective with a third exposure portion that exposes a third pixel electrode of the pixel electrodes, and forming a third intermediate layer on the third pixel electrode, wherein each of the first and second blocking layers includes a self-assembled monolayer.

11 Claims, 10 Drawing Sheets

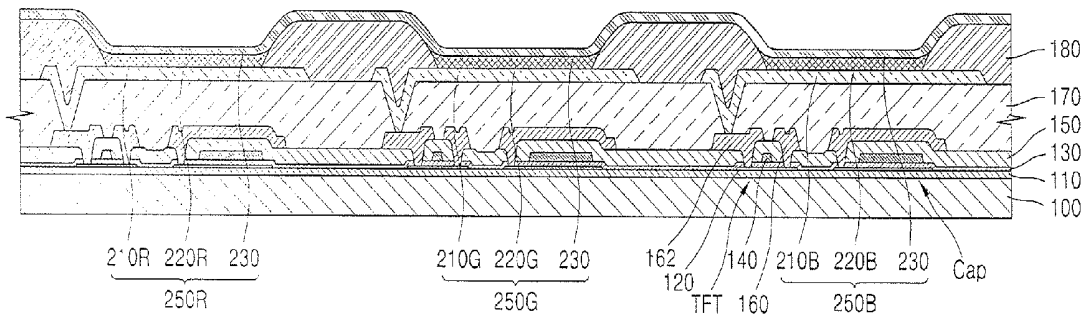

(52) **U.S. Cl.**
CPC *H01L 51/0094* (2013.01); *H01L 51/5253*
(2013.01); *H01L 2227/323* (2013.01)

(56) **References Cited**

U.S. PATENT DOCUMENTS

2008/0146011 A1* 6/2008 Yoon B82Y 30/00
438/584
2010/0289019 A1 11/2010 Katz et al.
2014/0120645 A1* 5/2014 Paek H01L 27/3211
438/35
2017/0256754 A1* 9/2017 Defranco H01L 51/56

FOREIGN PATENT DOCUMENTS

KR 10-2014-0082089 A 7/2014
KR 10-1677024 B1 11/2016
WO WO 2016/153230 A1 9/2016

* cited by examiner

FIG. 1

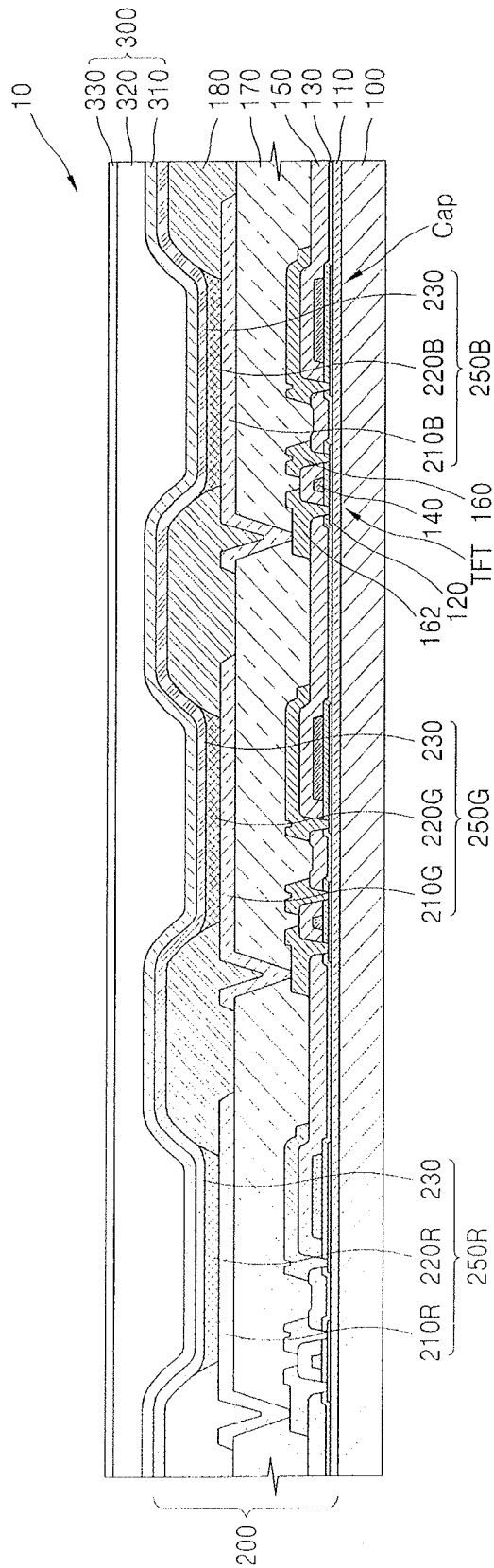

FIG. 2

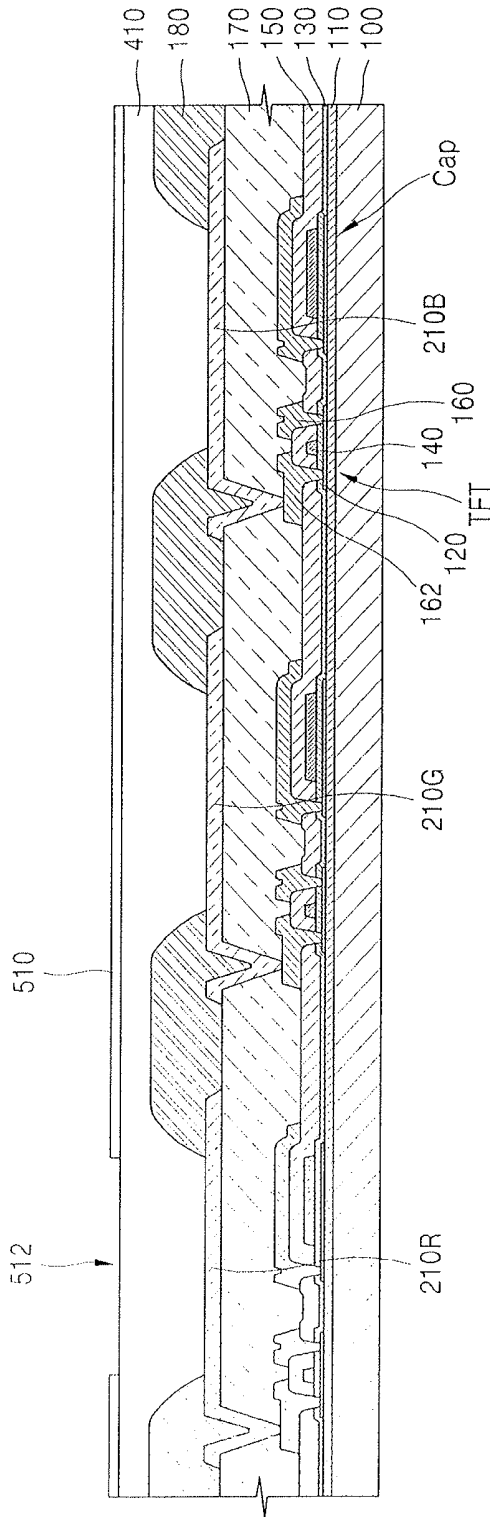

FIG. 3

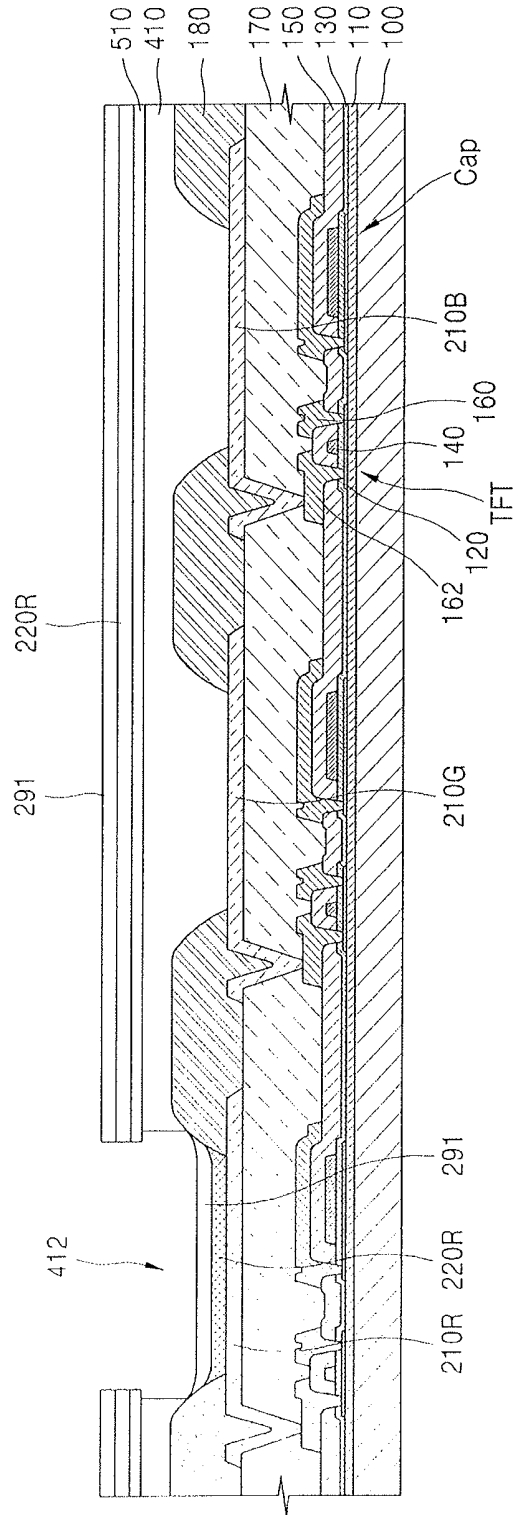

FIG. 5

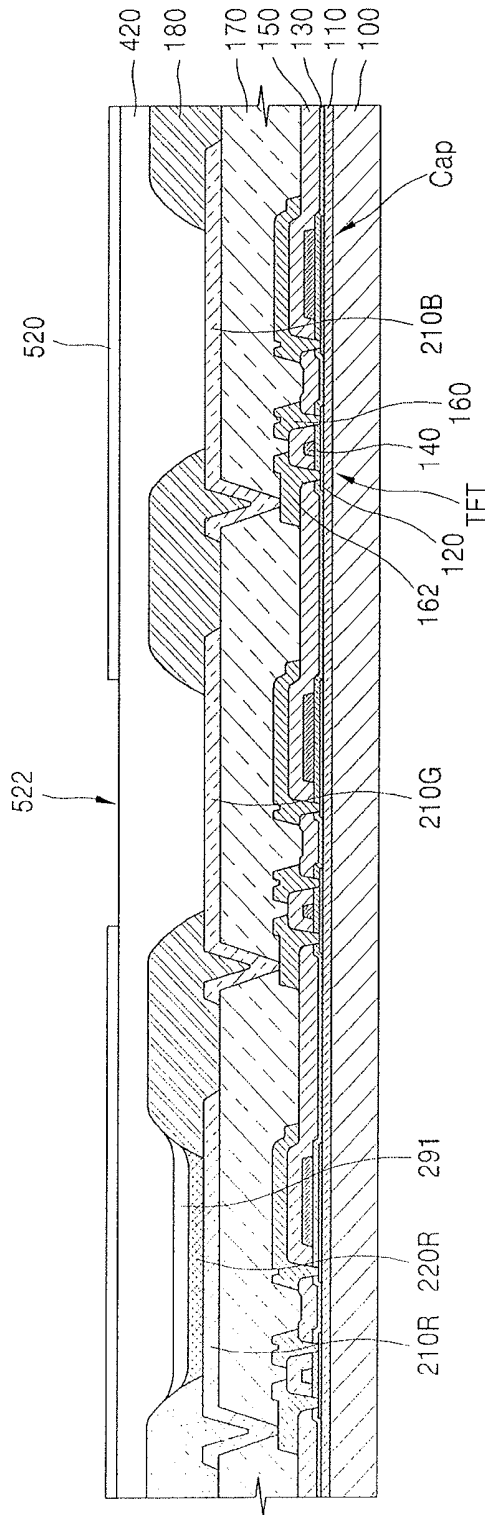

FIG. 6

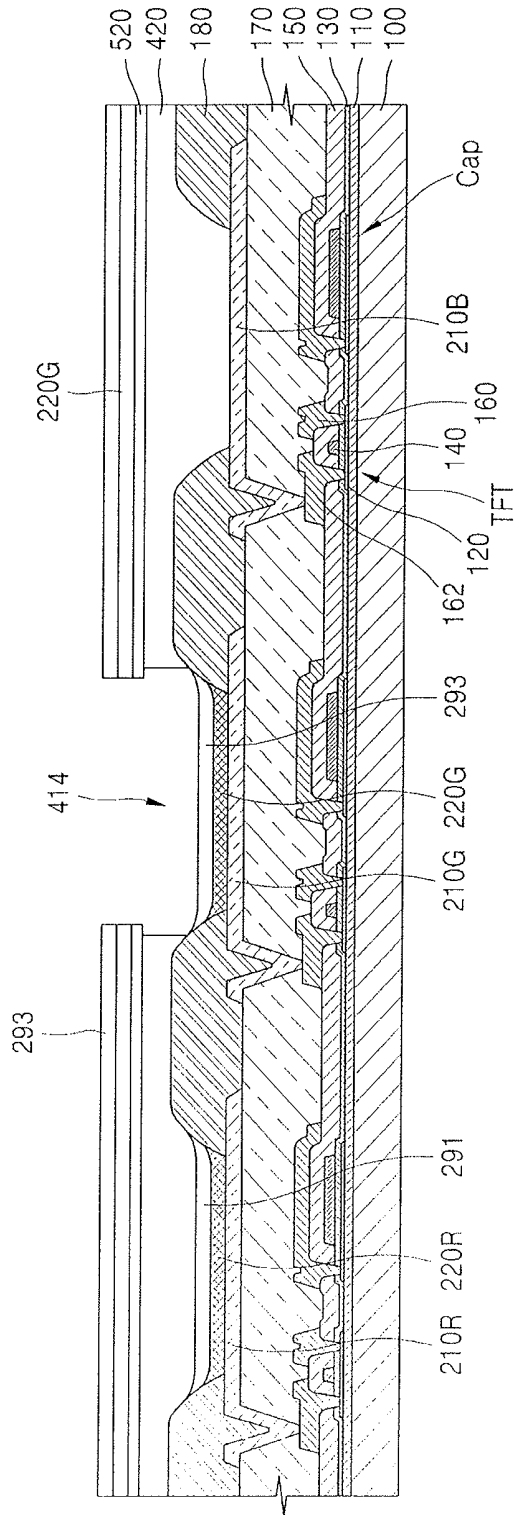

FIG. 7

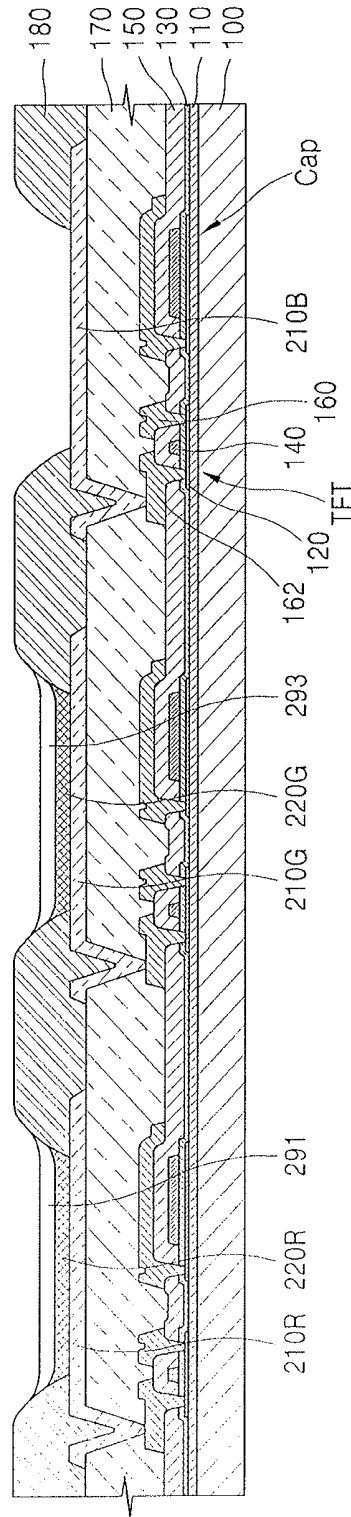

FIG. 8

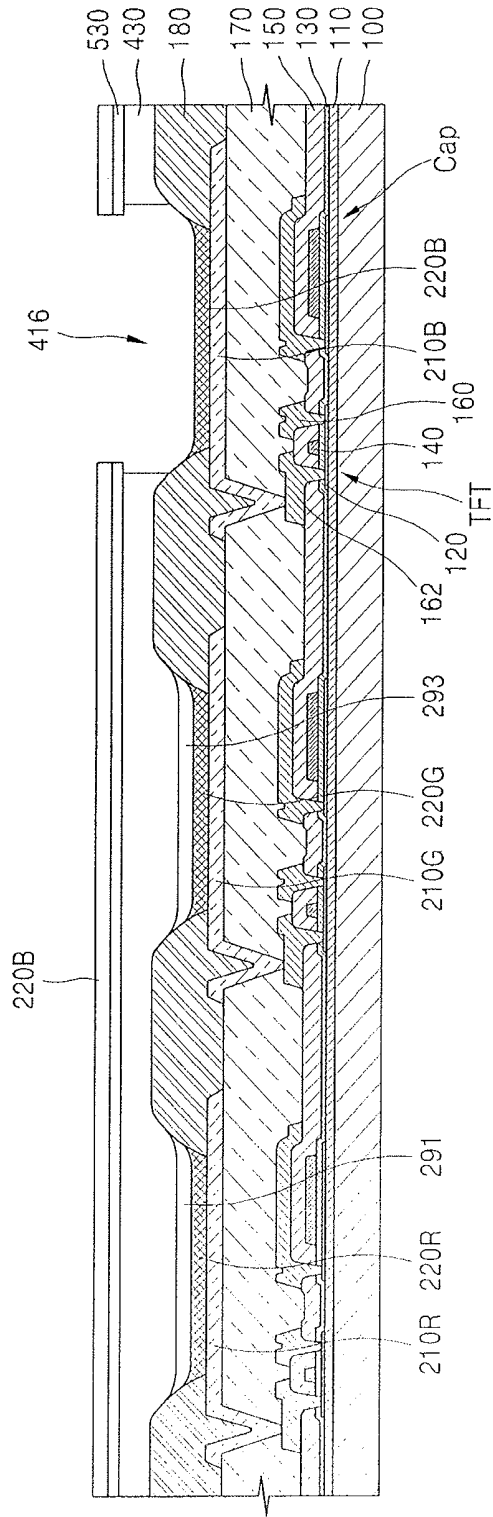

FIG. 9

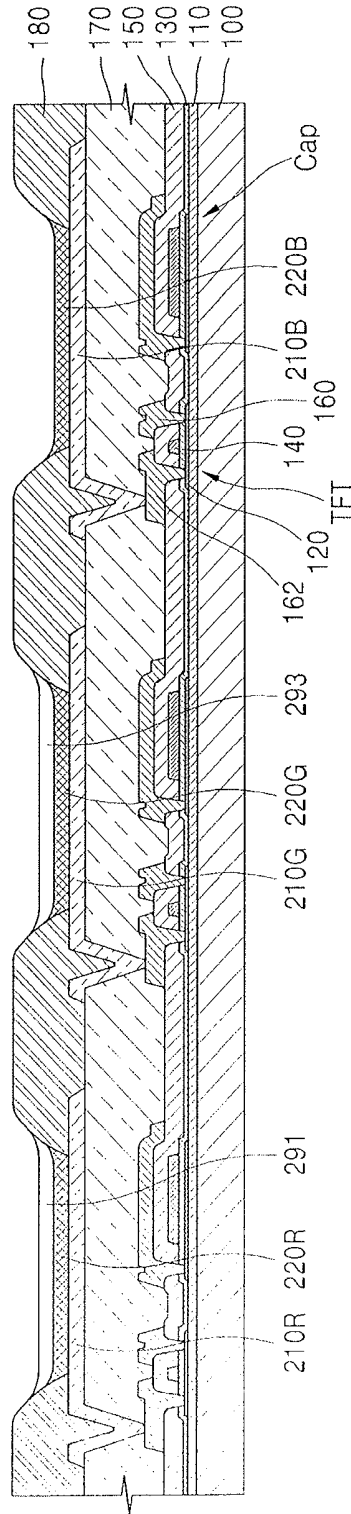
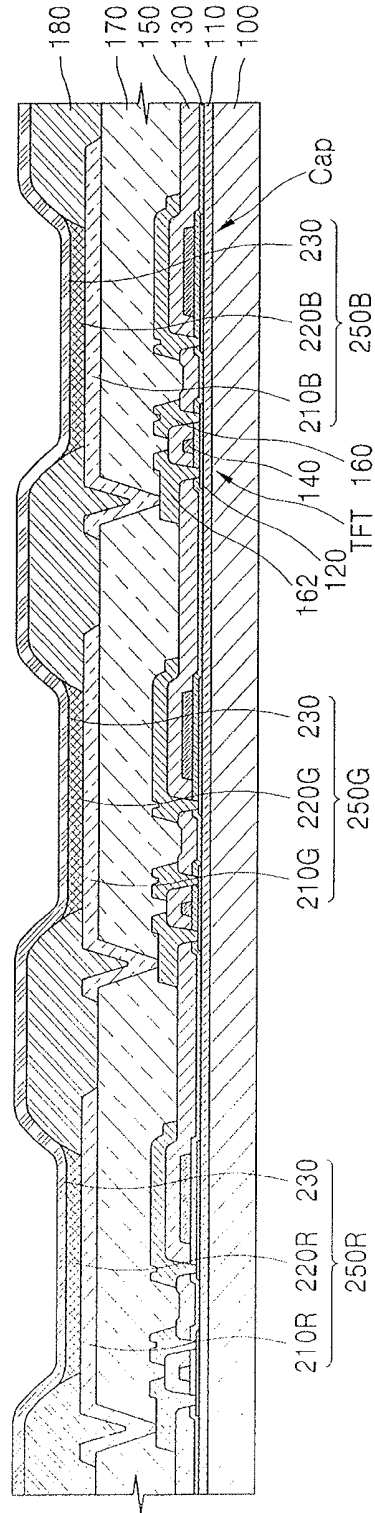

FIG. 10



METHOD OF MANUFACTURING ORGANIC LIGHT-EMITTING DISPLAY DEVICE

CROSS-REFERENCE TO RELATED APPLICATION

Korean Patent Application No. 10-2017-0036921, filed on Mar. 23, 2017, in the Korean Intellectual Property Office, and entitled: "Method Of Manufacturing Organic Light-Emitting Display Device," is incorporated by reference herein in its entirety.

BACKGROUND

1. Field

One or more embodiments relate to a method of manufacturing an organic light-emitting display device.

2. Description of the Related Art

An organic light-emitting display device, which is a self-emissive display device, does not require a separate light source. Thus, the organic light-emitting display device may be driven by low voltage, may be configured as a lightweight thin type display device, and is gaining attention as a next-generation display device due to high-quality characteristics, e.g., a wide viewing angle, a high contrast ratio, and a high response speed.

SUMMARY

According to one or more embodiments, a method of manufacturing an organic light-emitting display device may include forming a plurality of pixel electrodes on a substrate, forming a first protective layer over the plurality of pixel electrodes, such that a first exposure portion through the first protective layer exposes a first pixel electrode of the plurality of pixel electrodes, forming a first intermediate layer and a first blocking layer on the first pixel electrode, such that the first blocking layer covers the first intermediate layer, removing the first protective layer, forming a second protective layer over the plurality of pixel electrodes, such that a second exposure portion through the second protective layer exposes a second pixel electrode of the plurality of pixel electrodes, forming a second intermediate layer and a second blocking layer on the second pixel electrode, such that the second blocking layer covers the second intermediate layer, removing the second protective layer, forming a third protective layer over the plurality of pixel electrodes, such that a third exposure portion through the third protective layer exposes a third pixel electrode of the plurality of pixel electrodes, and forming a third intermediate layer on the third pixel electrode, wherein each of the first blocking layer and the second blocking layer includes a self-assembled monolayer.

In the present embodiment, the self-assembled monolayer may include a chain including at least one of a fluorine-based polymer and a hydrocarbon-based polymer, and a head group including an organic-inorganic silane compound.

In the present embodiment, the fluorine-based polymer may include at least one of perfluoropolyether, vinylidene fluoride, tetrafluoroethylene, hexafluoropropylene, and chlorotrifluoroethylene, and the hydrocarbon-based polymer may include at least one of octadecyltrichloro and dichlorodimethyl.

In the present embodiment, the organic-inorganic silane compound may include at least one functional group from

among an amino group, a vinyl group, an epoxy group, an alkoxy group, a halogen group, a mercapto group, and a sulfide group.

In the present embodiment, the forming of the first blocking layer and the second blocking layer may include vacuum-depositing a blocker on each of the first intermediate layer and the second intermediate layer, the blocker formed by polymerizing and condensing the at least one of the fluorine-based polymer and the hydrocarbon-based polymer with the organic-inorganic silane compound.

In the present embodiment, the first exposure portion may be formed by coating the first protective layer with a first photosensitive resin layer, forming a first groove by partially exposing and etching the first photosensitive resin layer, and then etching the first protective layer via the first groove.

In the present embodiment, a size of the first exposure portion may be greater than that of the first groove.

In the present embodiment, the method may further include removing the third protective layer and the first and second blocking layers.

In the present embodiment, the method may further include forming an opposite electrode on the first intermediate layer, the second intermediate layer, and the third intermediate layer.

In the present embodiment, the method may further include forming a thin film encapsulation layer on the opposite electrode.

In the present embodiment, a plurality of thin film transistors electrically connected to the plurality of pixel electrodes may be formed above the substrate.

In the present embodiment, forming the first protective layer may include forming the first exposure portion to expose only the first pixel electrode, while the second and third pixel electrodes are covered by the first protective layer

BRIEF DESCRIPTION OF THE DRAWINGS

Features will become apparent to those of skill in the art by describing in detail exemplary embodiments with reference to the attached drawings, in which:

FIG. 1 illustrates a schematic cross-sectional view of an example of an organic light-emitting display device according to an embodiment; and

FIGS. 2 to 10 illustrate schematic cross-sectional views of stages in a method of manufacturing the organic light-emitting display device of FIG. 1.

DETAILED DESCRIPTION

Example embodiments will now be described more fully hereinafter with reference to the accompanying drawings; however, they may be embodied in different forms and should not be construed as limited to the embodiments set forth herein. Rather, these embodiments are provided so that this disclosure will be thorough and complete, and will fully convey exemplary implementations to those skilled in the art.

In the drawing figures, the dimensions of layers and regions may be exaggerated for clarity of illustration. It will also be understood that when a layer or element is referred to as being "on" another layer or substrate, it can be directly on the other layer or substrate, or intervening layers may also be present. In addition, it will also be understood that when a layer is referred to as being "between" two layers, it can be the only layer between the two layers, or one or more intervening layers may also be present. Like reference numerals refer to like elements throughout.

While such terms as “first” and “second” may be used to describe various components, such components must not be limited to the above terms. The above terms are used only to distinguish one component from another.

The singular forms “a,” “an,” and “the” used herein are intended to include the plural forms as well, unless the context clearly indicates otherwise. Further, it will be understood that terms such as “include,” “comprise,” and “have” used herein specify the presence of stated features or components, but do not preclude the presence or addition of one or more other features or components.

When an embodiment may be implemented differently, a specific process order may be performed differently from the described order. For example, two consecutively described processes may be performed substantially at the same time or performed in an order opposite to the described order.

As used herein, the term “and/or” includes any and all combinations of one or more of the associated listed items. Expressions such as “at least one of,” when preceding a list of elements, modify the entire list of elements and do not modify the individual elements of the list.

FIG. 1 is a schematic cross-sectional view of an example of an organic light-emitting display device **10** according to an embodiment. FIGS. 2 to 10 are schematic cross-sectional views of stages in a method of manufacturing the organic light-emitting display device **10** of FIG. 1.

Referring to FIGS. 1 to 10, a method of manufacturing the organic light-emitting display device **10**, according to an embodiment, may include preparing a substrate **100** with a plurality of pixel electrodes **210R**, **210G**, and **210B**, and using a first protective layer **410** including a first exposure portion **412**, which exposes a first pixel electrode **210R** from among the plurality of pixel electrodes **210R**, **210G**, and **210B**, to form a first intermediate layer **220R** and a first blocking layer **291** covering the first intermediate layer **220R** over the first pixel electrode **210R**. The method may further include removing the first protective layer **410**, and by using a second protective layer **420** including a second exposure portion **414** which exposes a second pixel electrode **210G** from among the pixel electrodes **210R**, **210G**, and **210B**, forming, over the second pixel electrode **210G**, a second intermediate layer **220G** and a second blocking layer **293** covering the second intermediate layer **220G**. The method may further include removing the second protective layer **420**, and by using a third protective layer **430** including a third exposure portion **416** which exposes a third pixel electrode **210B** from among the pixel electrodes **210R**, **210G**, and **210B**, forming a third intermediate layer **220B** on the third pixel electrode **210B**.

After the third intermediate layer **220B** is formed, the third protective layer **430** and the first and second blocking layers **291** and **293** may be removed, and an opposite electrode **230** may be formed on the first intermediate layer **220R**, the second intermediate layer **220G**, and the third intermediate layer **220B**. The pixel electrodes **210R**, **210G**, and **210B** may be respectively electrically connected to a plurality of thin film transistors TFT formed above the substrate **100**, and a plurality of capacitors Cap may be formed above the substrate **100** together with the plurality of thin film transistors TFT. Each of the thin film transistors TFT may include an active layer **120**, a gate electrode **140**, a source electrode **160**, and a drain electrode **162**.

In detail, referring to FIGS. 1-2, formation of the thin film transistors TFT and the pixel electrodes **210R**, **210G**, and **210B** electrically connected to the thin film transistors TFT on the substrate **100** will be described first.

The substrate **100** may include a transparent glass material, e.g., mainly composed of SiO₂. However, the substrate **100** is not limited thereto, and may include a transparent plastic material. The plastic material used to form the substrate **100** may be an insulating organic material, and may be at least one of, e.g., polyethersulfone (PES), polyacrylate, polyetherimide (PEI), polyethylene naphthalate (PEN), polyethylene terephthalate (PET), polyphenylene sulfide (PPS), polyarylate (PAR), polyimide (PI), polycarbonate (PC), cellulose triacetate (TAC), and cellulose acetate propionate (CAP).

In a bottom emission type, i.e., where an image is implemented toward the substrate **100**, the substrate **100** needs to include a transparent material. However, in a top emission type, i.e., where an image is implemented in an opposite direction to the substrate **100**, the substrate **100** does not need to include a transparent material. In this case, the substrate **100** may include metal. When the substrate **100** includes metal, the substrate **100** may include, but is not limited to, at least one of, e.g., carbon, steel, chromium (Cr), manganese (Mn), nickel (Ni), titanium (Ti), molybdenum (Mo), and stainless steel (SUS).

As illustrated in FIG. 2, a buffer layer **110** may be formed on the substrate **100** to prevent intrusion of impurities, etc. into the active layer **120** of a thin film transistor TFT. The buffer layer **110** may include an inorganic material, e.g., silicon oxide, silicon nitride, silicon oxynitride, aluminum oxide, aluminum nitride, titanium oxide, or titanium nitride, or an organic material, e.g., PI, polyester, or acryl, or may have a stack structure of these materials. The buffer layer **110** may be deposited by using various deposition methods, e.g., a plasma-enhanced chemical vapor deposition (PECVD) method, an atmospheric pressure CVD (APCVD) method, or a low pressure CVD (LPCVD) method.

The active layer **120** including an inorganic semiconductor, e.g., silicon, an organic semiconductor, or an oxide semiconductor material may be formed on the buffer layer **110**. The active layer **120** has a source region, a drain region, and a channel region therebetween. For example, when the active layer **120** is formed by using amorphous silicon, an amorphous silicon layer is formed on the entire surface of the substrate **100** and then crystallized to form a polycrystalline silicon layer. After the polycrystalline silicon layer is patterned, a source region and a drain region at opposite edges thereof are doped with impurities to form the active layer **120** including a source region, a drain region, and a channel region between the doped source and drain regions.

A gate insulating film **130** may be formed on the active layer **120**. The gate insulating film **130**, which insulates the active layer **120** and the gate electrode **140** from each other, may include, e.g., SiN_x or SiO₂.

The gate electrode **140** may be formed above the active layer **120** with the gate insulating film **130** therebetween. The gate electrode **140** may be formed of at least one of, e.g., aluminum (Al), platinum (Pt), palladium (Pd), silver (Ag), magnesium (Mg), gold (Au), Ni, neodymium (Nd), iridium (Ir), Cr, lithium (Li), calcium (Ca), Mo, Ti, tungsten (W), and copper (Cu), in a single layer or a multilayer structure.

An interlayer insulating film **150** may be formed on the gate electrode **140**. The interlayer insulating film **150** may be formed of, e.g., silicon oxide or silicon nitride, in a single layer or a multilayer structure.

The source electrode **160** and the drain electrode **162** are formed on the interlayer insulating film **150** to finalize the thin film transistor TFT. In detail, the interlayer insulating film **150** and the gate insulating film **130** expose the source region and the drain region of the active layer **120**. The

source electrode **160** and the drain electrode **162** contact the exposed source and drain regions of the active layer **120**, respectively. The source electrode **160** and the drain electrode **162** may be formed of at least one of, e.g., Al, Pt, Pd, Ag, Mg, Au, Ni, Nd, Ir, Cr, Li, Ca, Mo, Ti, W, and Cu, in a single layer or a multilayer structure.

Although FIG. 1 illustrates a top gate-type thin film transistor TFT sequentially including the active layer **120**, the gate electrode **140**, the source electrode **160**, and the drain electrode **162**, the present disclosure is not limited thereto. For example, the gate electrode **140** may be disposed below the active layer **120**.

A first insulating film **170** may be formed on the source electrode **160** and the drain electrode **162**, e.g., to cover a plurality of thin film transistors TFT on the substrate **100**. When an organic light-emitting device is disposed above the thin film transistor TFT, the first insulating film **170** may planarize an upper surface of the thin film transistor TFT and may protect the thin film transistors TFT and various devices. The first insulating film **170** may include an inorganic insulating film and/or an organic insulating film. The inorganic insulating film may include, e.g., SiO₂, SiN_x, SiON, Al₂O₃, TiO₂, Ta₂O₅, HfO₂, ZrO₂, BST, or PZT. The organic insulating film may include, e.g., a commodity polymer (PMMA or PS), polymer derivatives containing a phenol-based group, an acrylic polymer, an imide-based polymer, an aryl ether-based polymer, an amide-based polymer, a fluorine-based polymer, a p-xylene-based polymer, a vinyl alcohol-based polymer, or a blend thereof. Also, the first insulating film **170** may be a complex stack of an inorganic insulating film and an organic insulating film.

Organic light-emitting devices including a first sub-pixel **250R**, a second sub-pixel **250G**, and a third sub-pixel **250B** may be formed on the first insulating film **170**. For example, the first sub-pixel **250R** may be a red sub-pixel, the second sub-pixel **250G** may be a green sub-pixel, and the third sub-pixel **250B** may be a blue sub-pixel. The first sub-pixel **250R** may include the first pixel electrode **210R**, the first intermediate layer **220R**, and the opposite electrode **230**, the second sub-pixel **250G** may include the second pixel electrode **210G**, the second intermediate layer **220G**, and the opposite electrode **230**, and the third sub-pixel **250B** may include the third pixel electrode **210B**, the third intermediate layer **220B**, and the opposite electrode **230**.

In detail, as illustrated in FIG. 2, the first to third pixel electrodes **210R**, **210G**, and **210B** may be formed on the first insulating film **170**, may be respectively connected to the thin film transistors TFT via contact holes formed in the first insulating film **170**, and may be transparent electrodes or reflective electrodes. When the first to third pixel electrodes **210R**, **210G**, and **210B** are transparent electrodes, the first to third pixel electrodes **210R**, **210G**, and **210B** may include, e.g., ITO, IZO, ZnO, In₂O₃, IGO, or AZO. When the first to third pixel electrodes **210R**, **210G**, and **210B** are reflective electrodes, the first to third pixel electrodes **210R**, **210G**, and **210B** may include a reflective film including, e.g., Ag, Mg, Al, Pt, Pd, Au, Ni, Nd, Ir, Cr, or a compound thereof, and a layer including, e.g., ITO, IZO, ZnO, In₂O₃, IGO, or AZO. However, the present disclosure is not limited thereto. The first to third pixel electrodes **210R**, **210G**, and **210B** may include various materials, and a structure thereof may also be variously modified so that the first to third pixel electrodes **210R**, **210G**, and **210B** may have, for example, a single layer or multi-layer structure.

A second insulating film **180** may be formed on the first to third pixel electrodes **210R**, **210G**, and **210B**. The second insulating film **180** may include at least one organic insu-

lating material of, e.g., PI, polyamide, an acrylic resin layer, benzocyclobutene, and a phenol resin layer, and may be formed by, e.g., spin coating. The second insulating film **180** may be a pixel-defining film exposing predetermined regions of the first to third pixel electrodes **210R**, **210G**, and **210B**.

The first intermediate layer **220R**, the second intermediate layer **220G**, and the third intermediate layer **220B** respectively included in the first sub-pixel **250R**, the second sub-pixel **250G**, and the third sub-pixel **250B** may be formed in pixel regions defined by the second insulating film **180**, and may respectively include emission layers (EMLs) respectively emitting red colored light, green colored light, and blue colored light. In addition, the first intermediate layer **220R**, the second intermediate layer **220G**, and the third intermediate layer **220B** may include a hole injection layer (HIL), a hole transport layer (HTL), an electron transport layer (ETL), an electron injection layer (EIL), and the like stacked in a single or complex structure, and may have various structures. Also, a metal film including, e.g., Ag and Mg, may be included on top of the first intermediate layer **220R**, the second intermediate layer **220G**, and the third intermediate layer **220B**.

Hereinafter, a method of forming the first intermediate layer **220R**, the second intermediate layer **220G**, and the third intermediate layer **220B** above the pixel electrodes **210R**, **210G**, and **210B**, respectively, will be described in more detail below with reference to FIGS. 2-3.

First, referring to FIG. 2, the first protective layer **410** may be formed above the substrate **100** so as to cover the, e.g., entire, second insulating film **180** and, e.g., all, the exposed portions of the pixel electrodes **210R**, **210G**, and **210B**. Next, a first photosensitive resin layer **510** may be formed on the top surface of the first protective layer **410**, and a first groove **512** may be formed through the first photosensitive resin layer **510** in a region overlapping the first pixel electrode **210R**.

Referring to FIG. 3, the first exposure portion **412** exposing the first pixel electrode **210R** may be formed through the first protective layer **410**. Then, the first intermediate layer **220R** and the first blocking layer **291** may be, e.g., sequentially, formed over the first pixel electrode **210R**.

The first protective layer **410** may cover not only the pixel electrodes **210R**, **210G**, and **210B** but also the second insulating film **180**. For example, the first protective layer **410** may include a fluorine-based resin. That is, the first protective layer **410** is unreactive with an organic material, and thus may be prevented from reacting with the second insulating film **180** including an organic material. For example, the first protective layer **410** may include, but is not limited to, 75 wt % to 95 wt % of fluoro ether having hydrogen partially substituted with fluorine in an ether structure, and 5 wt % to 25 wt % of resin polymer.

The first exposure portion **412** may be formed by coating the first protective layer **410** with the first photosensitive resin layer **510**, forming the first groove **512** by partially exposing and etching the first photosensitive resin layer **510**, and then etching the first protective layer **410** via the first groove **512**. The first exposure portion **412** may be formed by wet-etching the first protective layer **410** by using a stripper capable of selectively removing the first protective layer **410**. For example, the first exposure portion **412** may be formed by removing the first protective layer **410** exposed via the first groove **512** by using a stripper in the form of a solution including hydro fluoro ether. As described above, the first exposure portion **412** may be formed by wet

etching, and thus, a size of the first exposure portion 412 may be greater than that of the first groove 512, as illustrated in FIG. 3.

The first intermediate layer 220R may be formed by a thermal deposition method, etc., so as to correspond to the entire area of the substrate 100. Accordingly, the first intermediate layer 220R may be formed not only on the first pixel electrode 210R but also on the first photosensitive resin layer 510. For example, a plurality of first intermediate layers 220R may be formed, e.g., simultaneously, on a plurality of corresponding first pixel electrodes 210R, while the second and third pixel electrodes 210G and 210B are covered by the first protective layer 410 (FIG. 3). For example, a plurality of first blocking layers 291 may be formed, e.g., simultaneously, on a plurality of corresponding first intermediate layers 220R, while the second and third pixel electrodes 210G and 210B are covered by the first protective layer 410 (FIG. 3).

The first intermediate layer 220R may include an EML, and may have an HIL, an HTL, an ETL, an EIL, and the like stacked in a single or complex structure. Also, a metal film including, e.g., Ag and Mg, may further be included on top of the first intermediate layer 220R.

The first blocking layer 291 may cover the, e.g., entire exposed surface of the, first intermediate layer 220R. The first blocking layer 291 may be formed by a vapor deposition method. The first blocking layer 291 may be formed not only on the first intermediate layer 220R in the first exposure portion 412, but also on the first intermediate layer 220R on the first photosensitive resin layer 510. Since the first exposure portion 412 is larger, e.g., wider along a direction parallel to the substrate 100, than the first groove 512, the first blocking layer 291 formed by the vapor deposition method may be deposited in a direction perpendicular to the substrate 100 and a direction oblique to the substrate 100, and thus may cover edges of the first intermediate layer 220R in the first exposure portion 412 having a width greater than that of the first groove 512. For example, as illustrated in FIG. 3, the first blocking layer 291 may extend to completely overlap and cover the upper surface of the first intermediate layer 220R, and may extend beyond edges of the first intermediate layer 220R to contact sidewalls of the second insulating film 180, e.g., so the first intermediate layer 220R may be completely enclosed by the first blocking layer 291, the first pixel electrode 210R, and the second insulating film 180.

The first blocking layer 291 may block exposure of the first intermediate layer 220R to a process environment during a process of forming the second intermediate layer 220G (of FIG. 1) and the third intermediate layer 220B (of FIG. 1), which will be described later, and thus may prevent damage to the first intermediate layer 220R. For example, as the first blocking layer 291 may completely cover the first intermediate layer 220R, the first intermediate layer 220R may be protected from any damage during subsequent processing stages, e.g., stages forming the second and third intermediate layers 220G and 220B.

Therefore, the first blocking layer 291 according to embodiments exhibits excellent binding strength with respect to the second protective layer 420 (of FIG. 5) and the third protective layer 430 (of FIG. 8) formed thereon during subsequent processes, and is stably maintained when the first protective layer 410, the second protective layer 420 (of FIG. 5), and the third protective layer 430 (of FIG. 8) are removed. At the same time, the first blocking layer 291 is easily removed from the first intermediate layer 220R without residue remaining on the first intermediate layer 220R

after the second intermediate layer 220G (of FIG. 1) and the third intermediate layer 220B (of FIG. 1) are formed.

That is, a first side, i.e., surface, of the first blocking layer 291 facing the first intermediate layer 220R and a second side, i.e., surface, opposite the first side of the first blocking layer 291 have different characteristics from each other. Accordingly, the first blocking layer 291 may be a self-assembled monolayer. For example, the first blocking layer 291 may be a self-assembled monolayer including a chain, e.g., at least one of a fluorine-based polymer and a hydrocarbon-based polymer to have water repellency, and a terminal group, e.g., a head group of the polymer chain including an organic-inorganic silane compound binding to the first intermediate layer 220R.

The fluorine-based polymer and the hydrocarbon-based polymer have low surface energy and thus may have excellent binding strength with respect to the second protective layer 420 (of FIG. 5) and the third protective layer 430 (of FIG. 8). For example, the fluorine-based polymer may include at least one of perfluoropolyether, vinylidene fluoride, tetrafluoroethylene, hexafluoropropylene, and chlorotrifluoroethylene, and the hydrocarbon-based polymer may include at least one of octadecyltrichloro and dichlorodimethyl, but the present disclosure is not limited thereto.

The organic-inorganic silane compound may perform condensation and polymerization reactions with the fluorine-based polymer and/or the hydrocarbon-based polymer, and may include an adhesion promoter for increasing adhesive strength with respect to the first intermediate layer 220R. For example, the organic-inorganic silane compound may have at least one functional group from among an amino group, a vinyl group, an epoxy group, an alkoxy group, a halogen group, a mercapto group, and a sulfide group.

In detail, the organic-inorganic silane compound may include at least one of aminopropyltriethoxysilane, aminopropyltrimethoxysilane, amino-methoxysilane, phenylaminopropyltrimethoxysilane, N-(2-aminoethyl)-3-aminopropyltrimethoxysilane, N-(β -aminoethyl)- γ -aminopropylmethyldimethoxysilane, γ -aminopropyltrimethoxysilane, γ -aminopropyldimethoxysilane, γ -aminopropyltriethoxysilane, γ -aminopropyldiethoxysilane, vinyltriethoxysilane, vinyltrimethoxysilane, vinyltri(methoxyethoxy)silane, di-, tri- or tetraalkoxysilane, vinylmethoxysilane, vinyltrimethoxysilane, vinyl epoxy silane, vinyltriethoxysilane, 3-glycidoxypropyltrimethoxysilane, 3-methacryloxypropyltrimethoxysilane, γ -glycidoxypropyltriethoxysilane, γ -methacryloxypropyltrimethoxysilane, chlorotrimethylsilane, trichloroethylsilane, trichloromethylsilane, trichlorophenylsilane, trichlorovinylsilane, mercaptopropyltriethoxysilane, trifluoropropyltrimethoxysilane, bis(trimethoxysilylpropyl)amine, bis(3-triethoxysilylpropyl) tetrasulfide, bis(triethoxysilylpropyl)disulfide, (methacryloxy)propyltrimethoxysilane, 2-(3,4-epoxycyclohexyl)ethyltrimethoxysilane, 3-glycidoxypropylmethyldiethoxysilane, 3-glycidoxypropyldiethoxysilane, 3-glycidoxypropyltriethoxysilane, and p-styryltrimethoxysilane.

The first blocking layer 291 may be formed by mixing at least one of the fluorine-based polymer and the hydrocarbon-based polymer with the organic-inorganic silane compound, forming a blocker for forming the first blocking layer 291 by polymerizing and condensing at least one of the fluorine-based polymer and the hydrocarbon-based polymer with the organic-inorganic silane compound in an inactive gas atmosphere, e.g., argon gas, and then vacuum-depositing the blocker. The formed first blocking layer 291 may include

at least one of, e.g., FOTS($\text{CF}_3(\text{CF}_2)_5(\text{CH}_2)_2\text{SiCl}_3$), FDTS($\text{CF}_3(\text{CF}_2)_7(\text{CH}_2)_2\text{SiCl}_3$), FOMDS($\text{CF}_3(\text{CF}_2)_5(\text{CH}_2)_2\text{Si}(\text{CH}_3)\text{Cl}_2$), FOMMS($\text{CF}_3(\text{CF}_2)_5(\text{CH}_2)_2\text{Si}(\text{CH}_3)_2\text{Cl}$), OTS($\text{CH}_3(\text{CH}_2)_{17}(\text{CH}_2)_2\text{SiCl}_3$), and DDMS($(\text{CH}_3)_2\text{SiCl}_2$).

As illustrated in FIG. 4, after the first blocking layer 291 is formed, the first protective layer 410 (of FIG. 3) is removed. The first protective layer 410 (of FIG. 3) may be removed by a stripper capable of selectively removing only the first protective layer 410 (of FIG. 3). For example, the first protective layer 410 (of FIG. 3) may be removed by a method of dipping the substrate 100 into a stripper in the form of a solution including hydro fluoro ether. In this regard, the first intermediate layer 220R is covered by the first blocking layer 291, and accordingly, when the first protective layer 410 (of FIG. 3) is removed, the first intermediate layer 220R is not exposed to the stripper while removing the first protective layer 410 (of FIG. 3).

Next, as illustrated in FIGS. 5 and 6, the second protective layer 420 may be formed above the substrate 100 so as to cover the pixel electrodes 210R, 210G, and 210B. The second exposure portion 414 exposing the second pixel electrode 210G may be formed in the second protective layer 420, and then, the second intermediate layer 220G and the second blocking layer 293 may be formed over the second pixel electrode 210G.

In detail, the second protective layer 420 may include the same material as that of the first protective layer 410 (of FIG. 3). Also, the second exposure portion 414 may be formed by the same method used to form the first exposure portion 412. That is, the second exposure portion 414 may be formed by coating the second protective layer 420 with a second photosensitive resin layer 520, forming a second groove by patterning the second photosensitive resin layer 520 through a photolithography process, and then etching the second protective layer 420 via the second groove.

The second intermediate layer 220G and the second blocking layer 293 may be formed so as to correspond to the entire area of the substrate 100, and thus may also be formed over the second photosensitive resin layer 520. Also, the second blocking layer 293 may be larger than the second intermediate layer 220G. The second blocking layer 293 may include the same material as that of the first blocking layer 291.

Next, as illustrated in FIG. 7, the second protective layer 420 (of FIG. 6) may be removed. The second protective layer 420 (of FIG. 6) may be removed by the same method used to remove the first protective layer 410 (of FIG. 3). In this regard, the first intermediate layer 220R and the second intermediate layer 220G are covered and protected by the first blocking layer 291 and the second blocking layer 293, respectively, and thus are not externally exposed during manufacturing processes.

Next, as illustrated in FIG. 8, the third protective layer 430 may be formed above the substrate 100 so as to cover the pixel electrodes 210R, 210G, and 210B. The third exposure portion 416 exposing the third pixel electrode 210B may be formed in the third protective layer 430, and then, the third intermediate layer 220B may be formed on the third pixel electrode 210B.

The third exposure portion 416 may be formed by the same method used to form the first exposure portion 412 and the second exposure portion 414. That is, the third exposure portion 416 may be formed by coating the third protective layer 430 with a third photosensitive resin layer 530, forming a third groove by patterning the third photosensitive resin layer 530 through a photolithography process, and then etching the third protective layer 430 via the third groove.

The third intermediate layer 220B may be formed so as to correspond to the entire area of the substrate 100, and thus may also be formed on the third photosensitive resin layer 530.

As illustrated in FIGS. 9 and 10, after the third intermediate layer 220B is formed, the third protective layer 430 (of FIG. 8) may be removed, the first blocking layer 291 and the second blocking layer 293 may be removed, and then, the opposite electrode 230 may be formed over the entire surface of the substrate 100.

The third protective layer 430 may be removed by the same method used to remove the first protective layer 410 (of FIG. 3) and the second protective layer 420 (of FIG. 6). In this regard, the first intermediate layer 220R and the second intermediate layer 220G are covered and protected by the first blocking layer 291 and the second blocking layer 293, respectively, and thus are not externally exposed during manufacturing processes. In a selective embodiment, a third blocking layer may be further formed on the third intermediate layer 220B. Accordingly, when the first intermediate layer 220R, the second intermediate layer 220G, and the third intermediate layer 220B are formed, external exposure of the first intermediate layer 220R, the second intermediate layer 220G, and the third intermediate layer 220B may be minimized, and thus, damage to the first intermediate layer 220R, the second intermediate layer 220G, and the third intermediate layer 220B may be prevented. Accordingly, reliability of the organic light-emitting display device 10 may increase.

The first blocking layer 291 and the second blocking layer 293 may be removed by various methods, e.g., thermal desorption, ion sputtering, mechanical polishing, or plasma oxidation. For example, the first blocking layer 291 and the second blocking layer 293 may be removed by nitrogen plasma treatment. The first blocking layer 291 and the second blocking layer 293 are self-assembled monolayers including at least one of the fluorine-based polymer and the hydrocarbon-based polymer as a chain, and including an organic-inorganic silane compound as a head group, and thus may be easily removed without residue remaining. Also, when the first blocking layer 291 and the second blocking layer 293 of the related art include ITO, a slip phenomenon of a driving voltage, i.e., a phenomenon in which an organic light-emitting device is not operated by an initial driving voltage and is driven by a higher voltage, may be prevented.

The opposite electrode 230 may be a transparent electrode or a reflective electrode. When the opposite electrode 230 is a transparent electrode, the opposite electrode 230 may have a layer including a metal having a low work function, e.g., Li, Ca, LiF/Ca, LiF/Al, Al, Ag, Mg, or a compound thereof, and a transparent conductive layer, e.g., ITO, IZO, ZnO, or In_2O_3 . When the opposite electrode 230 is a reflective electrode, the opposite electrode 230 may have a layer including, e.g., Li, Ca, LiF/Ca, LiF/Al, Al, Ag, Mg, or a compound thereof. However, a structure and a material of the opposite electrode 230 is not limited thereto, and may be variously modified.

Referring to FIG. 1 again, a thin film encapsulation layer 300 encapsulating a display layer 200 and preventing intrusion of external oxygen and moisture, etc. into the display layer 200 may be formed on the opposite electrode 230.

The thin film encapsulation layer 300 may include at least one inorganic film 310 and 330 and at least one organic film 320. For example, as illustrated in FIG. 1, the thin film encapsulation layer 300 may include a first inorganic film 310, an organic film 320, and a second inorganic film 330

stacked on one another in this stated order. However, the thin film encapsulation layer **300** is not limited thereto, and may have various structures.

The first inorganic film **310** and the second inorganic film **330** may include at least one of, e.g., silicon nitride, aluminum nitride, zirconium nitride, titanium nitride, hafnium nitride, tantalum nitride, silicon oxide, aluminum oxide, titanium oxide, tin oxide, cerium oxide, and silicon oxynitride (SiON). The organic film **320** may include at least one of, e.g., an acrylic resin layer, a methacrylic resin layer, polyisoprene, a vinyl-based resin layer, an epoxy-based resin layer, a urethane-based resin layer, a cellulose-based resin layer, and a perylene-based resin layer.

Although FIG. 1 illustrates an example in which the thin film encapsulation layer **300** is on the opposite electrode **230**, the present disclosure is not limited thereto. That is, the organic light-emitting display device **10** may include a sealing substrate instead of the thin film encapsulation layer **300**. The sealing substrate may be attached to the substrate **100** by a sealing member, e.g., a sealing glass frit, and may block external moisture and air, etc.

By way of summation and review, according to one or more embodiments, a method of forming an organic light-emitting display device includes sequentially forming intermediate layers on respective pixels electrodes, while forming a blocking layer on each of the intermediate layers to prevent damage to each covered intermediate layer during formation of subsequent intermediate layers. Accordingly, damage to an intermediate layer including an emission layer may be prevented during a process of manufacturing an organic light-emitting display device. Thus, reliability of the organic light-emitting display device may be increased.

Example embodiments have been disclosed herein, and although specific terms are employed, they are used and are to be interpreted in a generic and descriptive sense only and not for purpose of limitation. In some instances, as would be apparent to one of ordinary skill in the art as of the filing of the present application, features, characteristics, and/or elements described in connection with a particular embodiment may be used singly or in combination with features, characteristics, and/or elements described in connection with other embodiments unless otherwise specifically indicated. Accordingly, it will be understood by those of skill in the art that various changes in form and details may be made without departing from the spirit and scope of the present invention as set forth in the following claims.

What is claimed is:

1. A method of manufacturing an organic light-emitting display device, the method comprising:

forming a plurality of pixel electrodes on a substrate;

forming a first protective layer over the plurality of pixel electrodes, such that a first exposure portion through the first protective layer exposes a first pixel electrode of the plurality of pixel electrodes;

forming a first intermediate layer and a first blocking layer on the first pixel electrode, such that the first blocking layer covers the first intermediate layer;

removing the first protective layer;

forming a second protective layer over the plurality of pixel electrodes, such that a second exposure portion through the second protective layer exposes a second pixel electrode of the plurality of pixel electrodes;

forming a second intermediate layer and a second blocking layer on the second pixel electrode, such that the second blocking layer covers the second intermediate layer;

removing the second protective layer;

forming a third protective layer over the plurality of pixel electrodes, such that a third exposure portion through the third protective layer exposes a third pixel electrode of the plurality of pixel electrodes;

forming a third intermediate layer on the third pixel electrode; and

removing the third protective layer and the first and second blocking layers,

wherein each of the first blocking layer and the second blocking layer includes a self-assembled monolayer.

2. The method as claimed in claim 1, wherein the first exposure portion is formed by coating the first protective layer with a first photosensitive resin layer, forming a first groove by partially exposing and etching the first photosensitive resin layer, and then etching the first protective layer via the first groove.

3. The method as claimed in claim 2, wherein a size of the first exposure portion is greater than that of the first groove.

4. The method as claimed in claim 1, further comprising forming an opposite electrode on the first intermediate layer, the second intermediate layer, and the third intermediate layer.

5. The method as claimed in claim 4, further comprising forming a thin film encapsulation layer on the opposite electrode.

6. The method as claimed in claim 1, further comprising forming a plurality of thin film transistors electrically connected to the plurality of pixel electrodes on the substrate.

7. The method as claimed in claim 1, wherein forming the first protective layer includes forming the first exposure portion to expose only the first pixel electrode, while the second and third pixel electrodes are covered by the first protective layer.

8. A method of manufacturing an organic light-emitting display device, the method comprising:

forming a plurality of pixel electrodes on a substrate;

forming a first protective layer over the plurality of pixel electrodes, such that a first exposure portion through the first protective layer exposes a first pixel electrode of the plurality of pixel electrodes;

forming a first intermediate layer and a first blocking layer on the first pixel electrode, such that the first blocking layer covers the first intermediate layer;

removing the first protective layer;

forming a second protective layer over the plurality of pixel electrodes, such that a second exposure portion through the second protective layer exposes a second pixel electrode of the plurality of pixel electrodes;

forming a second intermediate layer and a second blocking layer on the second pixel electrode, such that the second blocking layer covers the second intermediate layer;

removing the second protective layer;

forming a third protective layer over the plurality of pixel electrodes, such that a third exposure portion through the third protective layer exposes a third pixel electrode of the plurality of pixel electrodes; and

forming a third intermediate layer on the third pixel electrode,

wherein each of the first blocking layer and the second blocking layer includes a self-assembled monolayer, and

wherein the self-assembled monolayer includes a chain with a head group, the chain including at least one of a fluorine-based polymer and a hydrocarbon-based polymer, and the head group including an organic-inorganic silane compound.

9. The method as claimed in claim 8, wherein the fluorine-based polymer includes at least one of perfluoropolyether, vinylidene fluoride, tetrafluoroethylene, hexafluoropropylene, and chlorotrifluoroethylene, and the hydrocarbon-based polymer comprises at least one of octadecyltrichloro and dichlorodimethyl. 5

10. The method as claimed in claim 8, wherein the organic-inorganic silane compound includes at least one functional group of an amino group, a vinyl group, an epoxy group, an alkoxy group, a halogen group, a mercapto group, and a sulfide group. 10

11. The method as claimed in claim 8, wherein forming the first blocking layer and the second blocking layer includes vacuum-depositing a blocker on each of the first intermediate layer and the second intermediate layer, the blocker being formed by polymerizing and condensing the at least one of the fluorine-based polymer and the hydrocarbon-based polymer with the organic-inorganic silane compound. 15

* * * * *

专利名称(译)	制造有机发光显示装置的方法		
公开(公告)号	US10236328	公开(公告)日	2019-03-19
申请号	US15/831829	申请日	2017-12-05
[标]申请(专利权)人(译)	三星显示有限公司		
申请(专利权)人(译)	三星DISPLAY CO. , LTD.		
当前申请(专利权)人(译)	三星DISPLAY CO. , LTD.		
[标]发明人	KIM JAESIK LEE YEONHWA LEE JOONGU JEONG SEHOON		
发明人	KIM, JAESIK LEE, YEONHWA LEE, JOONGU JEONG, SEHOON		
IPC分类号	H01L27/32 H01L51/52 H01L51/00		
CPC分类号	H01L27/3248 H01L27/3211 H01L51/0094 H01L51/5253 H01L51/004 H01L2227/323 H01L51/0017 H01L51/56		
优先权	1020170036921 2017-03-23 KR		
其他公开文献	US20180277612A1		
外部链接	Espacenet		

摘要(译)

一种制造有机发光显示装置的方法，包括在基板上形成像素电极，形成具有第一曝光部分的第一保护层，所述第一曝光部分暴露像素电极的第一像素电极，在第一像素电极上形成第一中间层覆盖第一中间层的第一阻挡层，去除第一保护层，用暴露像素电极的第二像素电极的第二曝光部分形成第二保护层，在第一像素电极上形成第二中间层和第二中间层阻挡层覆盖第二中间层，去除第二保护层，形成第三保护层，第三暴露部分暴露像素电极的第三像素电极，并在第三像素电极上形成第三中间层，其中每个第一和第二阻挡层包括自组装单层。

